

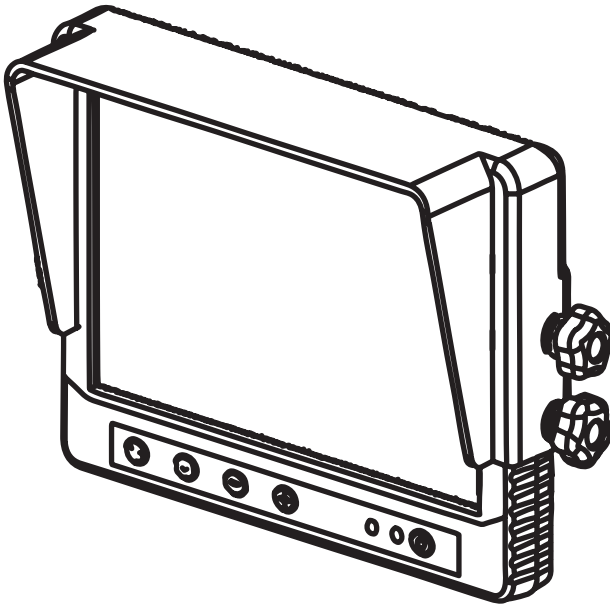

**rosco**  
VISION

**SAFE-T-SCOPE®**

BACKUP CAMERA SYSTEMS



**STSM270**  
7"HD LCD 4 CHANNEL MONITOR  
INSTALLATION/USER MANUAL

## TABLE OF CONTENTS

Introduction . . . . .	2
Component List and Description . . . . .	3
Monitor Installation . . . . .	4-5
Power Harness Installation . . . . .	6
Wiring Diagram . . . . .	7
Monitor Functions and Operations . . . . .	8
Available Split Screens and Camera Views . . . . .	9
Monitor Settings and Menus . . . . .	10-13
Video/Audio Output . . . . .	14
Appendix . . . . .	15-20

## STSM270 SAFE-T-SCOPE® 7" HD LCD 4 CHANNEL MONITOR KIT

Rosco Vision Systems introduces a revolutionary new camera system for commercial vehicles. The new Safe-T-Scope® camera system utilizes a 7" inch monitor to display a 800\*480 LCD screen which can accommodate 4 cameras along with the capability to show a particular view such as a single camera, a split screen, OR QUAD screen depending on what the user chooses.

This monitor allows the driver to see obstructions behind the vehicle as well as any other location based on the positioning of the cameras for added convenience and safety. The monitor auto adjusts the switches between day and night modes based on ambient light. Moreover, it complies with the latest FCC(USA) & guidelines when installed properly.



- To prevent electric shock, DO NOT OPEN THE MONITOR CASE. The components inside the monitor is carrying high voltage. There are no user serviceable parts.
- Avoid exposing monitor to water, rain, moisture etc. The monitor is not waterproof. Any moisture inside the monitor can cause extensive damage.

# COMPONENT LIST AND DESCRIPTION

**PART NO.**
**DESCRIPTION**

STSM270MO



7" HD LCD 4 Channel Monitor

STSM270PHAR

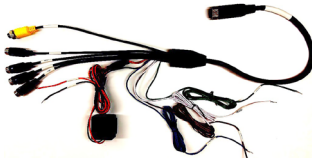

Power Harness equipped with 24 Pin Connector, 4 x 4 Pin Camera Inputs &amp; 4 Pin Video Output

BAS4515



Monitor Sun Shield

WAS2221



Washer, use only with Thumb Screw &amp; U-Bracket, not needed when sun shield is used

STSD1000



Duck-foot Mount (Mounting Option-1 of 2)

SCR9026



Monitor Angle Adjustment Thumb Screw, use only with U Bracket and/or sun shield

STSU1005



U-Bracket (Mounting Option- 2 of 2)

## MONITOR INSTALLATION

Find a mounting location inside the vehicle cabin that is convenient to the driver (e.g. center of the dashboard, above the windshield on the ceiling, near the rear view mirror etc). Installer needs to ensure he/she can drill a hole for the 24 pin connector, and that he/she can stow the power harness under a surface near the monitor (under the dash, headliner,etc). The STSM270 Monitor Kit offers 2 options for monitor installation:

### DUCK FOOT MOUNT INSTALLATION

- The mounting surface should be large enough to accommodate the duck foot mount, which is roughly 3x4 inches in size. Note that the duck foot is designed to bend and flex slightly in order to fit smoothly curved surfaces.
- Attach the "duck foot" bracket to the dashboard or to the headline using self tapping screws and/or adhesive pad.
- Slide the monitor to the "duck foot" mounting tip and secure the monitor using the locking ring on the mount. Adjust the monitor angle for optimum driver viewing comfort and tighten the knob to fix the monitor angle in place.

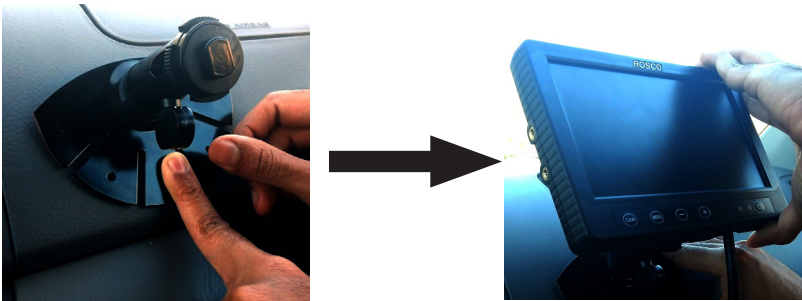

### U-BRACKET MOUNT INSTALLATION

- Attach the optional sunshade kit.
- Drill a hole for the 24 pin connector and ensure it lines up with the large hole in the center of the U-bracket. The hole diameter should not be more than 1 inch. Be sure to clear any obstacles before drilling holes. This hole should be the access point to the power harness via the 24 pin connection. Ensure the 24 pin connection is completely hidden.
- Attach the "U" bracket to the dashboard or to the headliner using self tapping screws.
- Fasten monitor to the U-bracket using the provided plastic thumb screws and adjust mounting angle to allow optimum driver viewing comfort. Firmly secure the viewing angle using the plastic thumb screws.



Attaching Sunshade



Attaching U bracket to vehicle.



Attaching monitor to U bracket using thumb screw

# MONITOR INSTALLATION

## DIFFERENT CONFIGURATIONS OF MONITOR INSTALLATION

### • Mounting Option 1: Duck Foot Mount

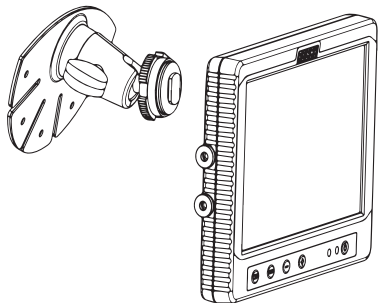

**fig. 1**

Monitor with the Duck Foot Mount

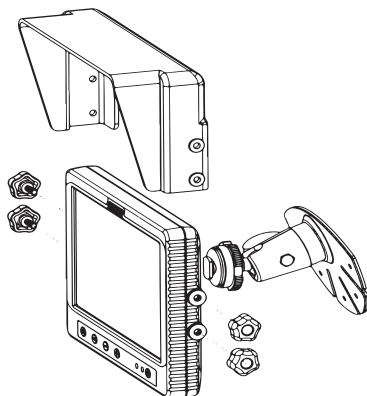

**fig. 2**

Monitor along with optional sunshade kit & Duck Foot Mount

### • Mounting Option 2: U Bracket Mount

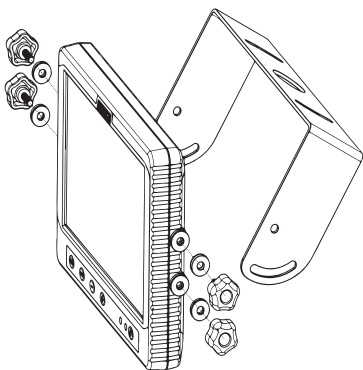

**fig. 3**

Monitor with U Bracket Mount

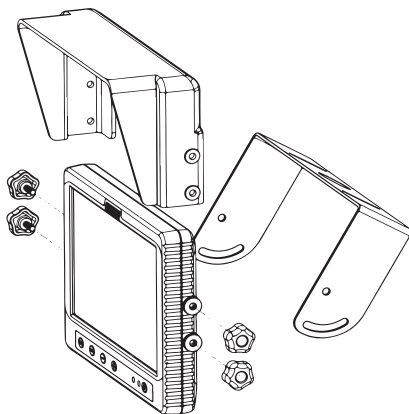

**fig. 4**

Monitor along with optional sunshade kit & U Bracket Mount

## POWER HARNESS INSTALLATION

- Once the monitor is mounted, if necessary, drill a hole on the monitor mounting surface near the monitor in which to pass through the monitor cable and 24-pin connector. The hole should be no larger than 1" in diameter. Be sure to clear any obstacles before drilling holes.
- Connect the black wire of the power harness to chassis ground. See wiring diagram on page 7 for connections.
- Connect the red wire to an ignition switched accessory (ex. radio) power source and ensure that the power source can provide operating current above 2 A.
- In order to automatically display the rear camera view when shifting into reverse using a backup camera setup, connect the green trigger wire to the vehicle's reverse light circuit. Ensure the backup camera is connected to port C1 on the power harness.. Similarly, trigger wires can be connected to the vehicle's left & right turn signal circuit to get the view of the blind spot while turning left/right.
- Connect the monitor 24 pin male connector to the power harness 24 pin connector.
- The power harness should be completely hidden from the vehicle operators and tied/clamped to a rigid structure or rigid existing vehicle harness.
- Adhere to a 2 inch bend radius for all cables to prevent damage.

### FUEL TANKERS & OTHER SPECIALTY VEHICLES:

- All electrical equipment fitted to petroleum vehicles must be connected via battery master switch and must be isolated from the battery while the vehicles are loading and unloading. For other specialty vehicles, please check applicable code and regulations prior to installation.
- Always consult your dealer when fitting any electrical or electronic equipment to a vehicle fitted with a CAN-bus multiplex system.



fig. 1

Power Harness 24 Pin Female Connector

Monitor 24 Pin Male Connector

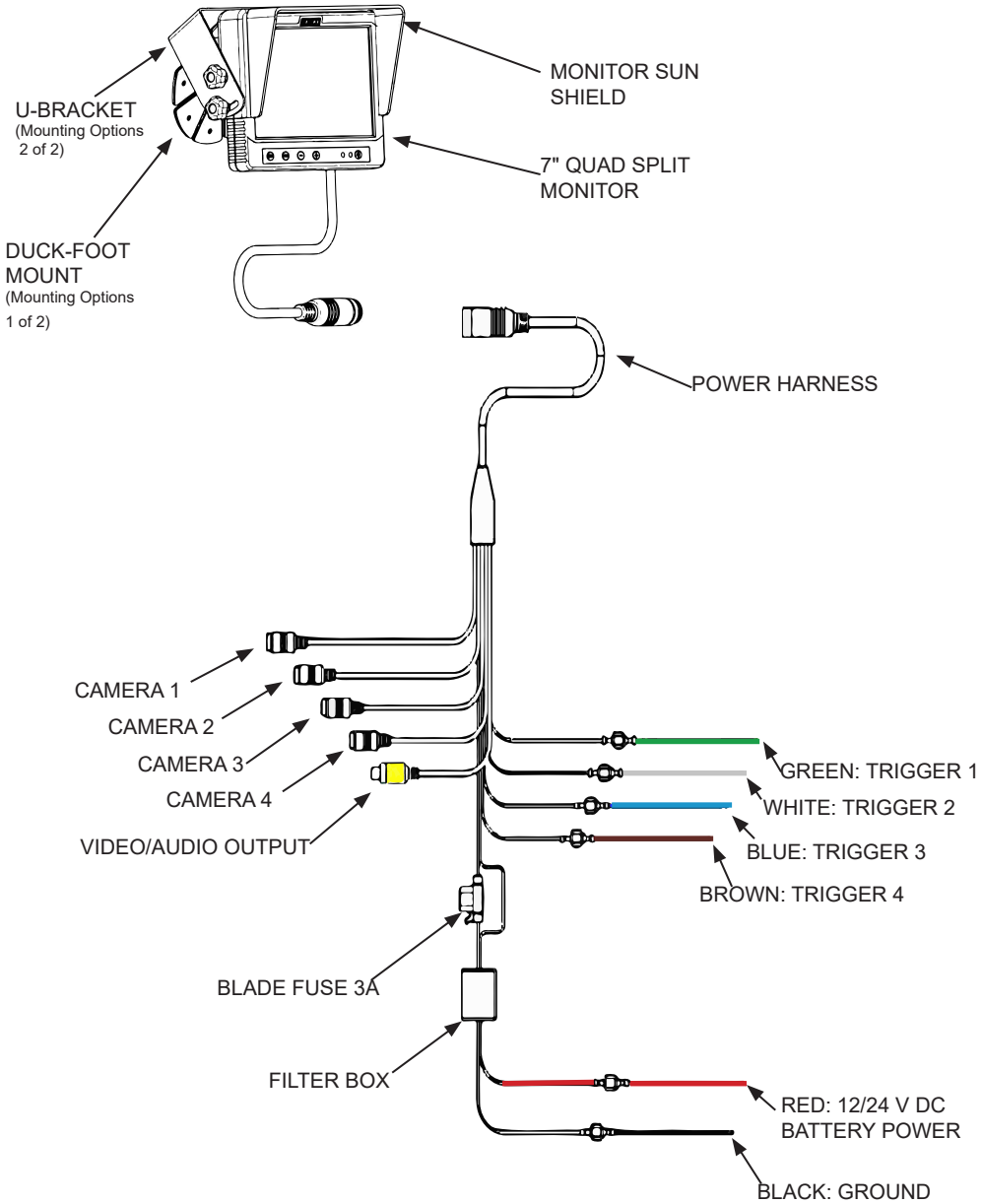

fig. 2

Note: Make sure that the arrow marks of both the connectors are lined up.

# STSM270

## Wiring Diagram



## MONITOR FUNCTIONS AND OPERATIONS

**i** NOTE: The monitor buttons do not function while the vehicle is in reverse. It is recommended that the buttons are ONLY used in park/neutral.



### POWER ON/OFF

Turns the LCD on or off. The monitor, however, is always fully on and functional when receiving power, whether or not the power button is used.



### LIGHT SENSOR (LEFT)

Used to adjust screen brightness automatically.

### POWER LED (RIGHT)

Green when LCD ON, Red when LCD OFF



### +/- VOLUME/MENU SETTING ADJUST BUTTONS

Decrease/Increase audio volume when no menu is open.



Go back/forward a menu page when no menu parameter is highlighted.

Decrease/increase the value for a particular menu parameter.



### MENU SETTING AND PAGE TOGGLE

Brings up the monitor settings menu. Press the button again to scroll through the various settings and to access the camera settings menu page (see following page).



### CAMERA CHANNEL TOGGLE

Toggles between different split screen views. If no camera is connected, the display will be black.

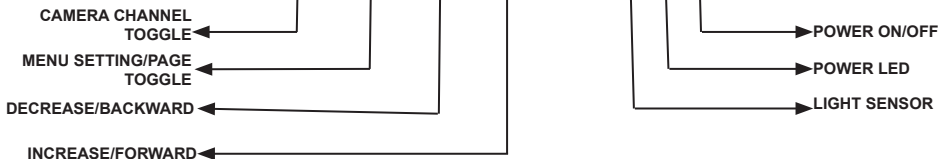



## AVAILABLE SPLIT SCREENS AND CAMERA VIEWS

- The below views can be accessed/triggered by the methods below:
- Pressing the "CAM" button for manual access
- Via triggering using the assignments on the "TRIGGER" monitor menu page. (Manual page 10)
- Default screen can be set on the "SYSTEM" monitor menu page (Manual page 12)

### CAM1/CAM2/CAM3/CAM4 (Single View)

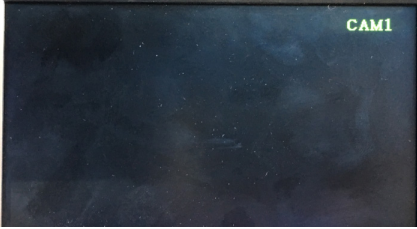

### CAM12



### CAM34

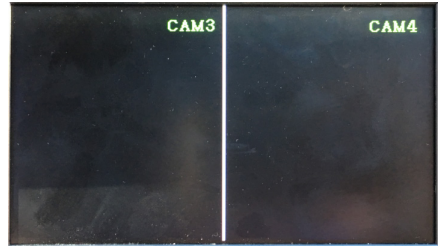

### V1-2



### 3CAM

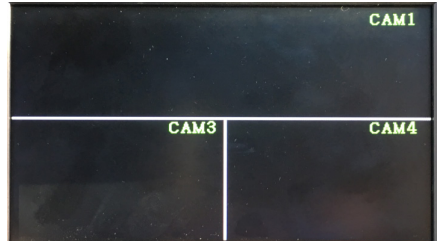

### 4-H

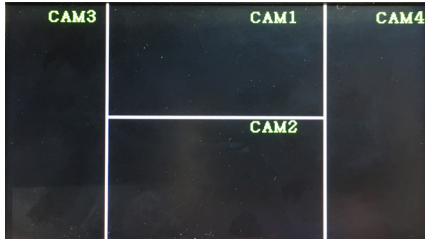

### QUAD

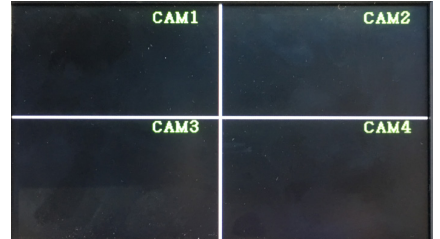

## MONITOR SETTINGS AND MENU

**i** NOTE: Press MENU button to enter the menu and "+" & "-" button to change pages. The menu cannot be accessed when any trigger is activated. Volume can still be adjusted with +/- if triggers are activated. The menu is closed after 10 sec without any operation.

### MENU SETTINGS PAGE 1:

#### "GENERAL SETTINGS"

Press the MENU button (see preceding page) to access this menu. Press the MENU button again to scroll through the settings:

Parameter	Options
BRIGHT	1~100 (DEFAULT 75 DAYTIME, DEFAULT 35 NIGHT TIME. THIS BRIGHTNESS SETTING CAN BE ADJUSTED FOR DAY AND NIGHT MODE INDIVIDUALLY TO ACHIEVE THE DESIRED BRIGHTNESS IN BOTH MODES.)
CONTRAST	1~100(DEFAULT 50)
COLOR	1~100(DEFAULT 50)
VOLUME	1~100(DEFAULT 50)
RESET	(Resets all settings back to factory default)
DAY MODE / NIGHT MODE (Denotes whether the monitor is applying daytime brightness or nighttime brightness, depending on the light sensor or the AUTO DIM setting in the SYSTEM menu page, see below. The "BRIGHT" setting 1-100 value will automatically adjust according to the Day/ Night mode)	
SOFTWARE VERSION (Shows the current firmware version of the monitor)	

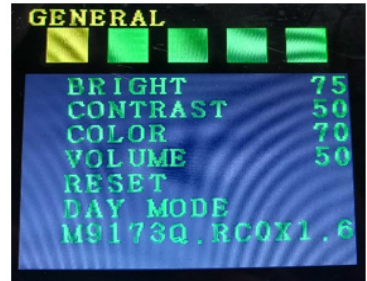

### MENU SETTINGS PAGE 2:

#### "TRIGGER ASSIGNMENT MENU"

This menu allows the user to assign a particular view to show for each trigger. Each trigger will show a particular view (such as a single camera, a split screen, OR QUAD screen depending on what the user chooses). Keep pressing the menu button to access page 2 of the settings:

Parameter	Options
TRIG1	CAM1(DEFAULT CAM1)
TRIG2	CAM2/CAM12(DEFAULT CAM2)
TRIG3	CAM3/4-H(DEFAULT CAM3)
TRIG4	CAM4/CAM34/4-QUAD(DEFAULT CAM4)



# MONITOR SETTINGS AND MENU

**i** NOTE: Press MENU button to enter the menu and "+" & "-" button to change pages. The menu cannot be accessed when any trigger is activated. Volume can still be adjusted with +/- if triggers are activated. The menu is closed after 10 sec. without any operation.

**PRACTICAL EXAMPLE:**

A 12V "door is open" signal can be connected to the white trigger 2 wire of the monitor. Trigger 2 can then be assigned to bring up a split screen. In this way, commuter or school bus drivers can simultaneously view 2 blind spots upon opening a door and loading/unloading passengers.



In a similar example, both vehicle turn signals can be diode isolated and tied to the white trigger 2 wire of the monitor. Trigger 2 can be assigned to bring up a split screen. Thus, whenever using the turn signals or hazards, the driver can simultaneously view a pair of side cameras, one on each blind spot of the vehicle, while executing consecutive turns.

**MENU SETTINGS PAGE 3:**

"CAM ORIENTATION VIEW MENU"

This menu allows the user to configure the mirroring of each camera channel and the channel labeling.

Parameter	Options
CAM1	MIRR/NORM(DEFAULT NORM)
CAM2	MIRR/NORM(DEFAULT NORM)
CAM3	MIRR/NORM(DEFAULT NORM)
CAM4	MIRR/NORM(DEFAULT NORM)
LABEL	MODE1/MODE2/MODE3/MODE4 (MODE1 DEFAULT) The LABEL MODE will set the channel labels. MODE1 is the default label configuration of CAM1, CAM2, etc. The other modes offer more specific labels such as LEFT/RIGHT to assist the driver in identifying the camera views.

**DIFFERENT LABEL OPTIONS:**

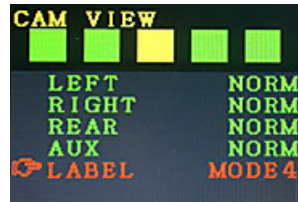

# MONITOR SETTINGS AND MENU

**i** NOTE: Press MENU button to enter the menu and "+" & "-" button to change pages. The menu cannot be accessed when any trigger is activated. Volume can still be adjusted with +/- if triggers are activated. The menu is closed after 10 sec. without any operation.

## MENU SETTINGS PAGE 4:

### "SYSTEM SETTINGS"

Press the menu button (see preceding page) to access this menu. Press the menu button again to scroll through the settings:

Parameter	Options
LANG	ENGLISH/ESPAÑOL (DEFAULT ENGLISH)
BLUE	ON/OFF (DEFAULT OFF for black screen) (If ON is chosen, a channel with no camera connected will show a blue screen. If OFF is chosen, a black screen will be shown instead. The blue screen is useful for troubleshooting. Note: if ON is chosen, after a video channel is un-triggered, the monitor will momentarily show a blue screen before shutting off the screen.)
AUTO-DIM	DAY/NIGHT/AUTO (DEFAULT AUTO) AUTO= The monitor will switch between Night mode and Day mode brightness by detecting the amount of ambient light using the light sensor. DAY= Manually sets the monitor to day mode. Night= Manually sets the monitor to night mode
STARTUP	CAM1 / CAM2 / CAM3 / CAM4 / CAM1&2 CAM3&4 / V1&2 / 3 CAM / 4-H / 4-QUAD (DEFAULT = 4-QUAD) This sets the default screen setup upon vehicle startup. Note: If OFF is chosen, the TURN-ON VIEW is the final view when shutting off the screen
BACK LITE	ON/OFF (DEFAULT ON) (This enables or disables the membrane button back-light. The backlight will be on whenever the monitor is in NIGHT mode, and off during DAY mode.)
PARKGRID	ON/OFF (DEFAULT ON) (Note: Only available when green trigger wire is activated)
GRID SIZE	Use the "-" button to switch between the park grid line to adjust. Use "+" to adjust the position and size of that particular line. Adjust it according to vehicle size.



Appearance of the Backup Grid

## MONITOR SETTINGS AND MENU

- i** NOTE: Press MENU button to enter the menu and "+" & "-" button to change pages. The menu cannot be accessed when any trigger is activated. Volume can still be adjusted with +/- if triggers are activated. The menu is closed after 10 sec. without any operation.

### MENU SETTINGS PAGE 5:

#### "TRIG OFF SETTINGS"

This menu allows the user to assign a particular TRIG OFF time for each individual camera. After the trigger wire is deactivated, the camera view will disappear only after the user-set delay time has elapsed. Press the MENU button (see preceding page) to access this menu. Press the menu button again to scroll through the settings:

Parameter	Options
CAM1	1~15 SEC(DEFAULT 3 SEC)
CAM2	1~15 SEC(DEFAULT 3 SEC)
CAM3	1~15 SEC(DEFAULT 3 SEC)
CAM4	1~15 SEC(DEFAULT 3 SEC)

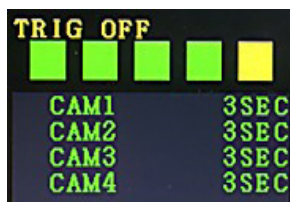

### PRACTICAL EXAMPLE:

A delay-off is useful when using turn signal triggers to activate a blind spot camera. Most vehicles automatically deactivate the turn signal half-way through a turn. The delay-off allows the driver to see the blind spot camera through the entire turn.



#### WARNING

- To prevent electrical shock, DO NOT OPEN MONITOR CASE.
- Avoid exposing monitor to water, rain, moisture etc.
- Do not disassemble the camera. This voids the warranty.

### NOTE

- Please read this manual carefully before using the product.
- This system is intended as an aid to safe driving operation.
- Drivers must always use extreme caution when operating a vehicle.
- Specifications subject to change without prior notice.
- Keep all cables AWAY from rotating and electrically noisy components.
- Make sure all cables are fastened properly so that you can prevent wire chafing, kinks, cuts, etc.
- Always consult your dealer when fitting any electrical or electronic equipment to a vehicle fitted with a CAN-bus or multiple system.

# VIDEO/AUDIO OUTPUT

## 2.1 VIDEO/AUDIO OUTPUT

Safe-T-Scope 7" Quad Split Monitor has an additional feature of video/audio output. The yellow colored 4 PIN FEMALE in the Power Harness cable of Monitor can be connected to a DV440 (Rosco Product) or to an auxiliary display. See schematic diagram example below.

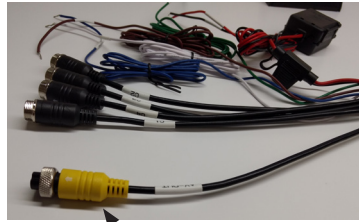

**fig 1**

VIDEO/AUDIO OUTPUT

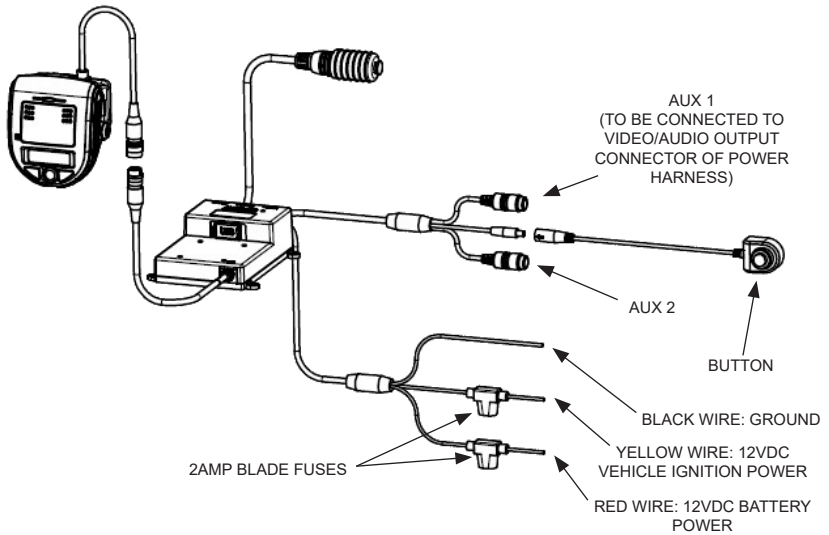

**fig. 2**

Rosco Part Number: DV440  
DVXC4 ADVANCED 4 CHANNEL HD  
PLUS WIFI AUTOMOTIVE VIDEO  
RECORDER

### STSM270 SETUP

- Set start up mode to Quad.

### DV440 SETUP

- Remove SD Card from DVXC4 Video Recorder.
- Place SD Card in computer.
- Open DV-PRO 5 Video Player Software.
- Click "SD CONFIG"
- Click "CHANNEL SETTING".
- Enable Channels 1,2,3,and 4.
- Insert SD Card into DVXC4 Video Recorder.

# APPENDIX

## 1.1 EXAMPLE CAMERA INSTALLATION

Safe-T-Scope 7" Quad Split Monitor can accommodate 1 to 4 cameras. These cameras can be installed at the rear of the vehicle, left/right side of the vehicle or any other location according to user's wish. An example of camera installation is given here using the STSC101 Rosco Backup Camera. **INSTALL MOUNTING BRACKET**

- Select a high and centered location at the rear of the vehicle and close to the rear marker lights to mount the STSC101A camera. This installation location will ensure that the image transmitted by the camera will show the rear bumper and area behind the vehicle.
- We do not recommend mounting the camera near the lower area of the vehicle (eg. the bumper). This reduces the view of the camera and increases the chance of physical damage to the camera.
- Using the camera mounting bracket as a guide, use a 3/16 drill bit to drill four screw holes into the vehicle. Be sure to clear any obstacles (e.g. electrical wiring), etc. before drilling holes. Use a 5/8 drill bit to drill a camera cable hole into the vehicle close to camera mounting bracket.

### INSTALL CAMERA

- Install the camera mounting bracket. Mount the camera and sunshade onto the bracket. Insert the camera cable into the vehicle through the hole and install the cable grommet on the hole.
- Connect the camera cable to the male-pinned connector of the camera extension cable. Hand-tighten the coupling ring on the camera cable to ensure a secure connection, and slide the environmental boot over the connection.

### ROUTE EXTENSION CABLE

- Route the extension cable to the vehicle cabin at the front of the vehicle and keep the cable away from hot, rotating, or electrically noisy components.
- Tuck the cable out of sight and secure/clamp the cable at as many spots as possible to prevent accidental snagging or damage to the cable.



Mounting Location: Rear of the vehicle

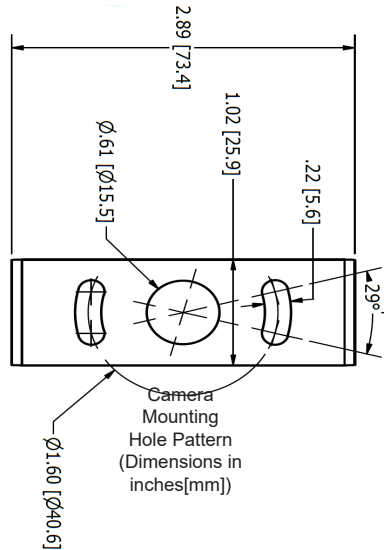

Typical Monitor Image from a properly installed camera

## APPENDIX

### 1.2 CAMERA WIRING EXAMPLE

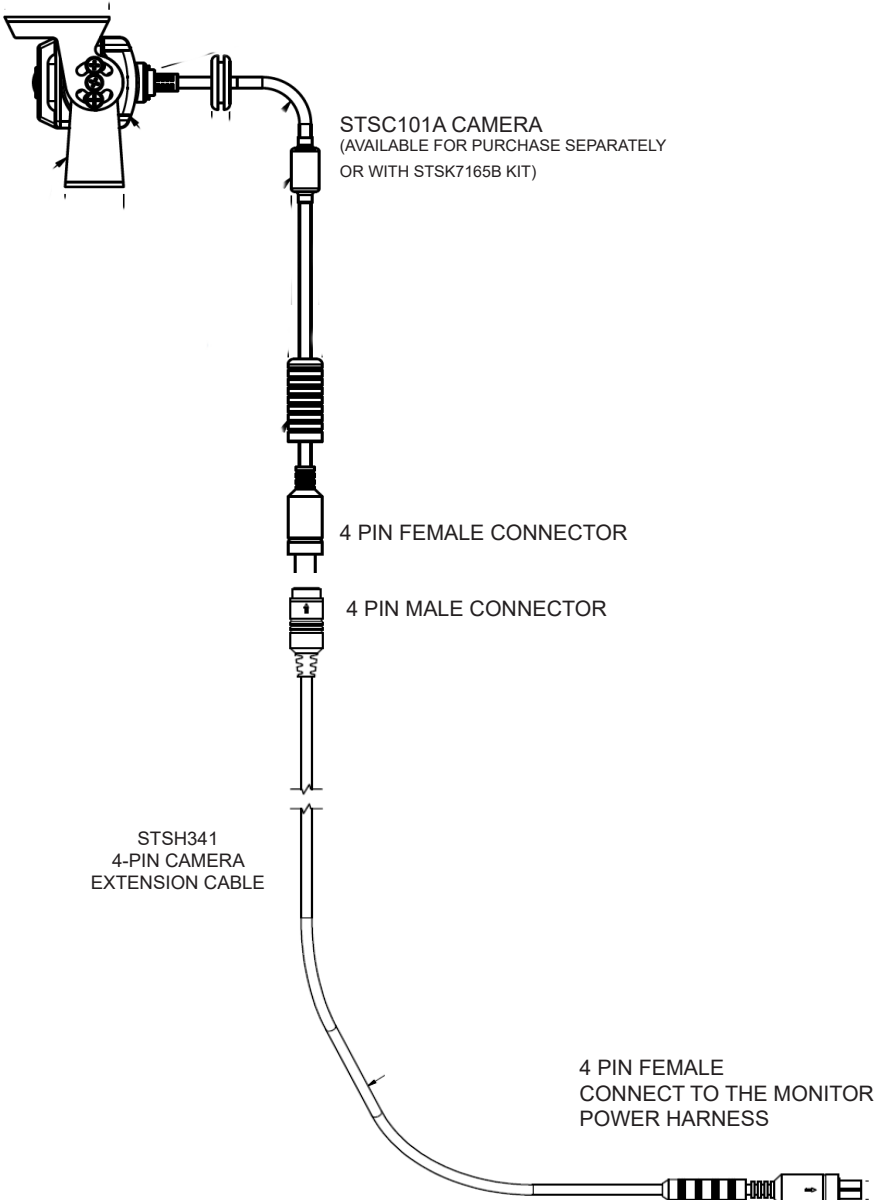



# APPENDIX

## 1.3 Example monitor application: STSK7165B Kit.

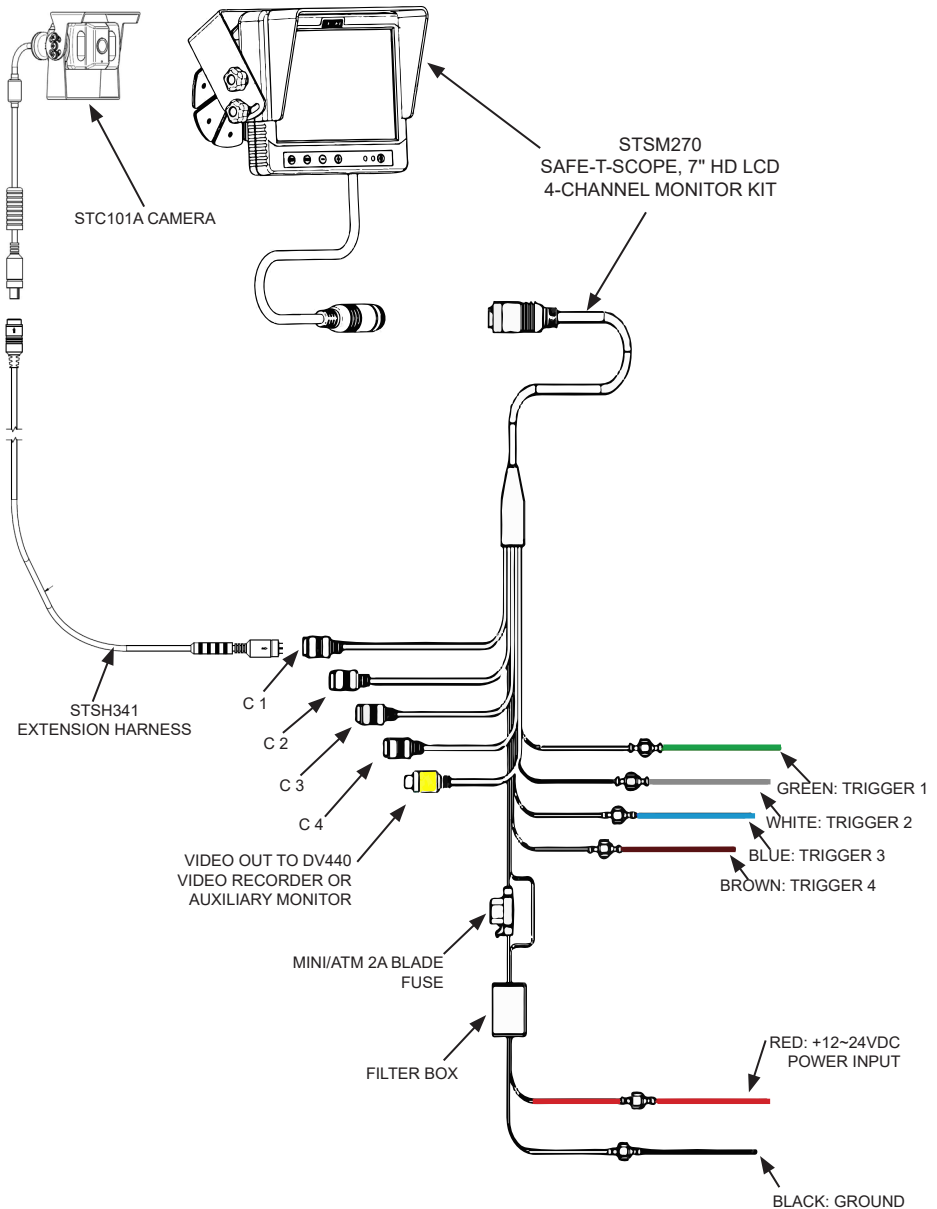

# APPENDIX

## 2.1 Connection With Vehicle Infotainment

Safe-T-Scope 7" 4 Channel Monitor is compatible with most vehicle infotainment systems as long as the vehicle provides RCA connectivity. Using the proper Rosco adapter harnesses, video can be sent to/from the Rosco monitor and vehicle infotainment system..

Two types of communication can be done here. The output (GPS, Auxiliary Video etc) from the vehicle Infotainment System can be transmitted to the 7" 4 Channel Monitor (fig.-1). As well, the output from the 7" 4 Channel Monitor (views of different cameras) can be transmitted to the vehicle infotainment system (fig.-2).

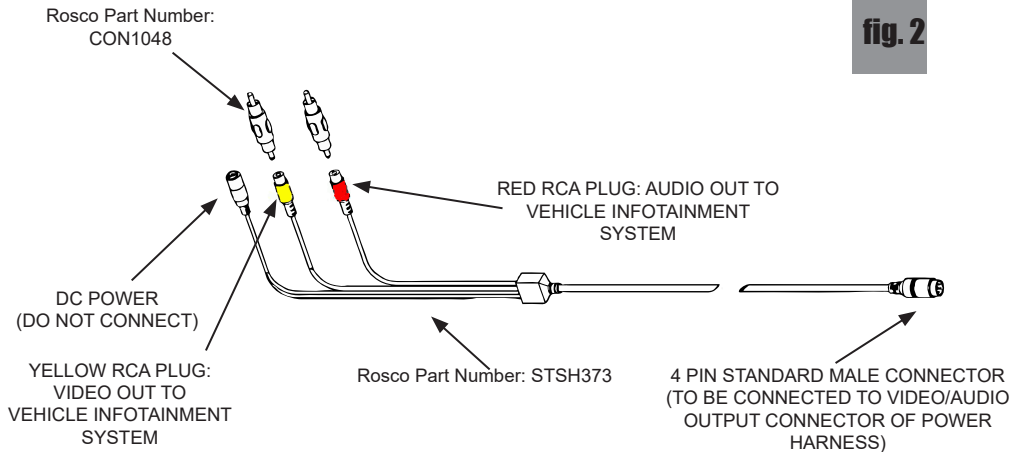
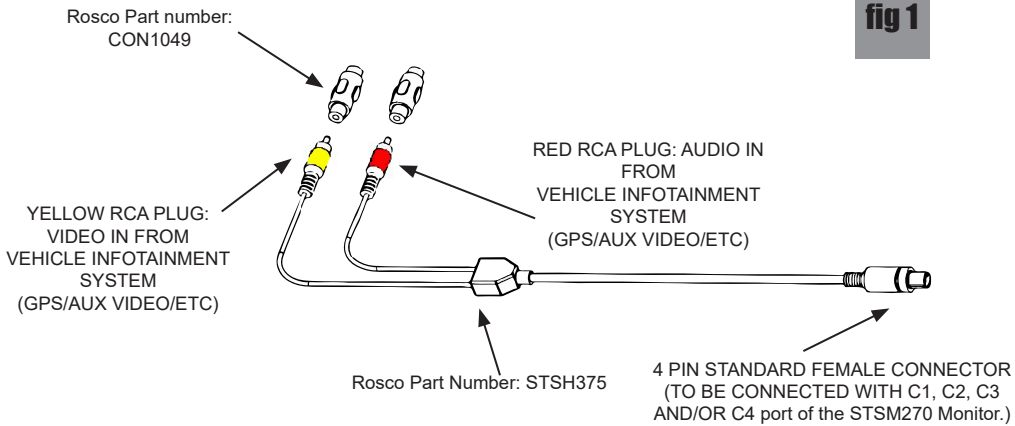

## APPENDIX

## STSM270

Technical specification

PARAMETER	VALUE
Function	7" Quad Split
TV System	NTSC
Resolution	800*480
Brightness	≥500cd/m <sup>2</sup>
Video Output	1Vp-p ±.2Vpp 75ohm
Power Supply	10~36 VDC
Power Consumption	≤8 W
Audio Out	1 W
Operating Current	600mA
Standby Current	≤ 400mA
Day/Night Mode	Auto
Vibration	6.8G@155Hz-30Hz, 4mm, for 0.5hours
Operating Temperature	-20°C to + 65°C (-4°F to +149°F)
Storage Temperature:	-40°C to + 80°C (-40°F to +176°F)



# rosco

## VISION

### ***A CENTURY OF AUTOMOTIVE VISION SAFETY***

90-21 144th Place, Jamaica, New York 11435

TEL (800) 227-2095 • FAX (718) 297-0323

[techsupport@roscovision.com](mailto:techsupport@roscovision.com)

[www.roscomirrors.com](http://www.roscomirrors.com)   [www.roscovision.com](http://www.roscovision.com)