

Pupil Transportation

Protecting our future with over
115 years of manufacturing
experience and engineering in
automotive vision safety.

www.roscovision.com



Contents

From mirrors to AI-powered cameras, safety in pupil transportation is our #1 priority.



Mirrors & Monitors

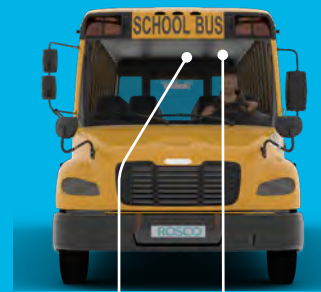

Rearview Mirrors
PAGE 04



Sun Visors
PAGE 04



Crossview Mirrors
PAGE 05



Mirror/Monitors
PAGE 10

Digital Solutions



360 HD SurroundView Camera System
PAGE 10



Collision Avoidance System
PAGE 16



Sensors
PAGE 09



Continuous HD Video Recording
PAGE 14



Digital Camera & Monitor System
PAGE 18



2 8 10 21 19 2 8 10 21 19





Rosco rearview mirrors are designed with the driver in mind. Our products are made for all school bus types and we supply to all the largest school bus OEMs in North America.



AccuStyle®

AccuStyle® mirror head can be mounted on mirror arms which are 3/4" O.D. tube up through 1-1/8" O.D. tube via the removable clamp cover on the back of the mirror shell – making OEM installation as well as aftermarket retrofit a breeze.



Open-View®

The Open-View® mirror system is a dynamic two head mirror configuration which offers a “view” between flat and convex mirrors for drivers who prefer to have a non-continuous image transition in the mirror lenses and adjustable forward sightline views around two separate mirrors.



The Rosco heavy duty class of sun visors is designed to stand up to the demands of today's bus industry. Only the finest heavy duty materials are used. The vinyl padding resists scratching, tearing and fading. Our standard line of acrylic sun visors are suitable for use when a see through visor is needed. These visors are an economical alternative to our heavy duty, padded line.

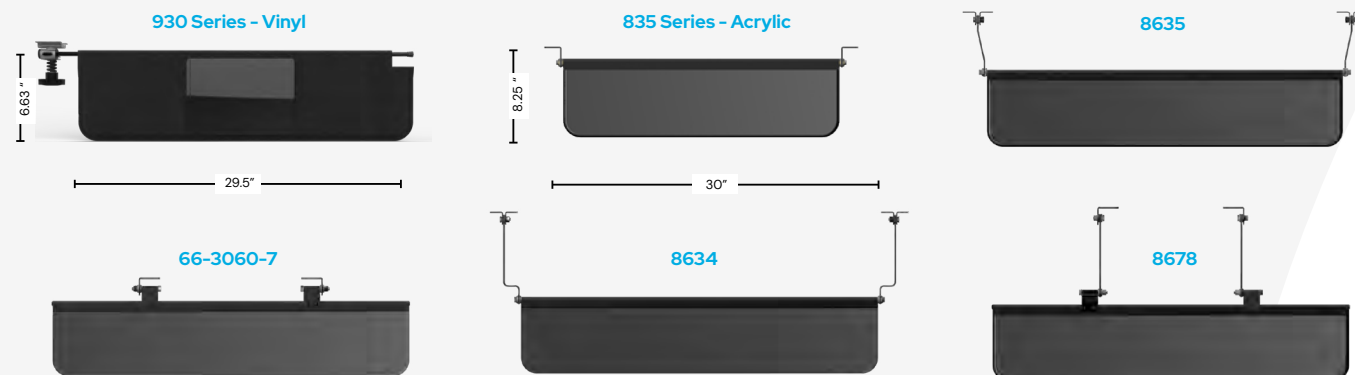

Crossview mirrors are a crucial tool for bus operators to safely maneuver large vehicles in all environments and offer a view of the front danger zone. Rosco's crossview mirrors offer low profiles reducing forward blind spots while enhancing coverage around the front of the bus.



Eye-Max® LP

Utilizing a revolutionary asymmetrical shaped mirror lens, the Eye-Max® LP is Rosco's most popular crossview mirror line.



HD®

The HD's unique lens properties take “danger zone” imaging beyond what other crossview mirrors can achieve in terms of image size, focus and overall clarity.

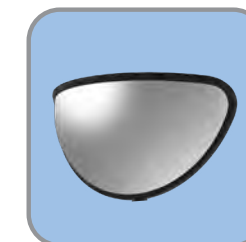

Safety Cross®

Available in multiple options, these quadraspheric lenses diminish sun glare while showing an enhanced reflected image size.



With a unique oval shape, Hawk-Eye® crossview mirrors provide a complete picture of the front of your bus and the areas around it.



LED Crossview Mirrors

EYE-MAX® LED & HD® LED

With front crossview mirror downlighting LEDs, visibility is increased in otherwise hard-to-see locations during low light conditions.



auto on when door is triggered

10 second shut off delay

universal wiring

easy installation on all vehicle types

replaceable LED components

lower profile

reduces forward blind spots and sun glare

assymetric mirror lens design

optimal field of vision (FOV)

In low light conditions, the reflection in any mirror is difficult to see. An object or pedestrians in front of the bus may be almost invisible.

NO ILLUMINATION



REFLECTION FROM DRIVER'S VIEW WITHOUT ILLUMINATION (HEADLIGHTS ON)

With the new LED under mounted lights, objects and pedestrians in front of the bus are clearly visible to the driver.

WITH ILLUMINATION



REFLECTION FROM DRIVER'S VIEW WITH ILLUMINATION (HEADLIGHTS ON)



5360LEDH Eye-Max® LED HEATED



BBHD380LED HD® LED HEATED

NO ILLUMINATION



WITH ILLUMINATION

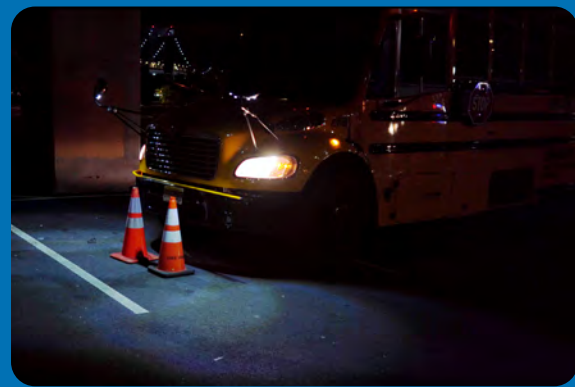

LED Crossview Mirrors

BUS MFR.	BUS MODEL	EXISTING C/V MIRROR	REPLACEMENT LED MIRROR PN
BLUE BIRD	VISION	EYE-MAX LP W/ 3/4" ARMS	KIT5360LEDHE
		EYE-MAX LP W/ 1" ARMS	KIT5360LEDHBB
	T3	EYE-MAX LP	KIT5360LEDHBB
IC BUS	CE	HAWK-EYE	S/S - KIT180395LED** B/S - KIT180380LED**
		HIGH DEFINITION	KIT380LEDH
	RE	HAWK-EYE	N/A
THOMAS BUILT BUSES	C2	HAWK-EYE W/ STAINLESS STEEL ARMS	KIT5360LEDHSSTC2*
		HAWK-EYE W/ BLACK STEEL ARMS	KIT5360LEDHBTC2*
		EYE-MAX LP	KIT5360LEDHTBB
	HDX	INTEGRASTYLE	N/A
	EFX	EYE-MAX LP	KIT5360LEDHTBB
	MINOTOUR	HAWK-EYE	N/A
COLLINS BUS	GM, FORD E-SERIES	FVF-MAX LP	KIT5360IFDHF
		EYE-MAX LP	KIT5360LEDHE
	FORD TRANSIT	SAFETY CROSS	N/A
MICRO-BIRD	DODGE PROMASTER	EYE-MAX LP	KIT5360LEDHE
	GM, FORD E-SERIES	EYE-MAX LP	KIT5360LEDHE
TRANSTECH	FORD TRANSIT	SAFETY CROSS	N/A
	GM, FORD E-SERIES	EYE-MAX LP	KIT5360LEDHE
TITAN	FORD TRANSIT	SAFETY CROSS	N/A
	GM, FORD E-SERIES	EYE-MAX LP	KIT5360LEDHE
STARCRAFT	GM, FORD E-SERIES	HAWK-EYE	N/A
VAN-CON	GM, FORD E-SERIES	HAWK-EYE	N/A
LION ELECTRIC	LION A, LION C, LION D	EYE-MAX LP	KIT5360LEDHBB

* KIT5360LEDHSSTC2 & KIT5360LEDHBTC2 include heads and replacement arms. If installed per the included instructions, the Thomas Built Bus C2 will comply with FMVSS 111.
** KIT180395 & KIT180380LED include heads and replacement arms. If installed properly by an IC B dealer or OEM, the IC CE BUS will be certified as FMVSS 111 compliant.



SCAN FOR THE LATEST PART NUMBER LIST.

Mounting Arms

Non-Detent Swivel Breakaway

Rosco's Non-Detent Swivel Arm Assembly is the industry standard. Its unique sandwich design provides unparalleled mirror assembly adjustment while being powerful enough to hold positions at highway speeds.



NON-DETENT SWIVEL ARM ASSEMBLY

ADJUSTABLE BY HAND YET POWERFUL ENOUGH TO HOLD POSITIONS AT HIGHWAY SPEEDS

Spring-Break® Detent

This line of mounting arms has a unique Spring Loaded Detent mechanism that dampens vibration and keeps the arm locked in position. Heavy-duty cast aluminum mount and swivel provide long lasting reliability and unequaled stability.



VARIETY OF MOUNTING BASES AND HOLE CONFIGURATIONS

MULTIPLE CUSTOM GROOVE LOCATIONS FOR VARIABLE DETENT ANGLES

HIDDEN INTERNAL SPRING DETENT MECHANISM

TUBULAR CONSTRUCTION FOR STRENGTH, CUSTOM LENGTH, AND HIDDEN WIRING.

Mirror Control Switches & Custom Wire Harnessing

A variety of switches, including heater controls and timers, are available to suit all requirements. Wire harnesses are available from stock or in custom lengths, with many different standard and weatherproof connectors.

Heater control switches available in toggle or momentary functionality with optional heater shut-off timer.



SW11010 - VERTICAL

SW11011 - HORIZONTAL

Illuminated membrane switches with combination heater and remote control functions for up to four lenses.

Rosco's family of remote control/heater membrane switches consolidates the function of two "knob" style remote switches and a separate heater switch into a small solid state package with illumination, circuit protection and unmatched durability.



HAR5020



HAR5012 (H/R/LED) or HAR5013 (H/R)

Remote control knob style switches available with or without illumination.

Rosco School Bus Safety Technology and Solutions



we are more than just mirrors...



BSSK1000 UNDERMOUNT

Rearview bumper ultrasonic wireless undermount sensor kit.

- (4) Undermount sensors
- (1) Transmitter Kit
- (1) Display Panel



BSSK4000 HARDWIRED

Heavy duty ultrasonic system with 4 rear bumper mount sensors & 2 roof sensors.

- (6) Sensors
- (2) Roof Mount Brackets
- (4) Undermount/Flushmount Brackets
- (1) Control Box
- (1) Display Panel

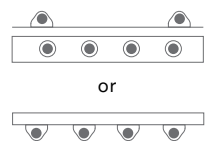

BSSK1001 FLUSHMOUNT

Rearview bumper ultrasonic wireless flush mount.

- (4) Flush mount sensors
- (1) Transmitter Kit
- (1) Display Panel



Mirror / Monitor Combo

MOR-VISION

The MOR-Vision® mirror/monitor series from Rosco offers automated safety for school buses. No driver input is required, and the camera view is activated when the driver shifts the bus into reverse. School buses equipped with MOR-Vision® have options for multiple cameras & automatic monitor view changes based on the operational conditions of the bus.



Mirror/ Monitor Options Include:

STSM1030 / STSM1030HD (HD)

10" X 30" MIRROR
7" Color Monitor

STSM630X

6" X 30" MIRROR
10" Color Monitor

STSM630 / STSM630HD (HD)

6" X 30" MIRROR
7" Color Monitor

STSM530 / STSM530HD (HD)

6" X 16" MIRROR

MOR-Vision® 6" x 30" Backup Camera System with Color Camera

Safety is a priority in pupil transportation and reversing buses creates a potentially dangerous situation. The combination of limited visibility and the need to maneuver around students and other vehicles requires the best in safety technology.



6" X 30" MIRROR
STSK6630



Rear Look Down or Side Mount Camera
Ultra Wide 170° FOV

STSC111B
STSC211B (HD)

IP69K | 170° FOV | NIGHT VISION



720 HD+ | 1080 HD+



Dome Camera
145° FOV

STSC172
STSC272 (HD)



Side Camera
145° FOV

STSC167 / STSC168
STSC267 / STSC268 (HD)



Rear Look Down Camera
150° FOV

STC101A
STSC201 (HD)



Rear Look Down Camera
150° FOV

STSC122 / STSC122U
STSC222 / STSC222U (HD)

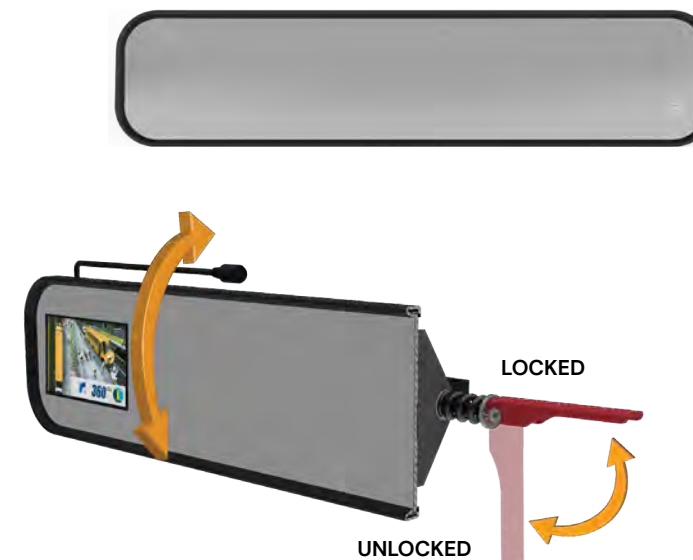

Optional LeverLock® add-on to MOR-Vision®

Add Rosco's patented LeverLock® to MOR-Vision® for effortless and tool free mirror adjustment by drivers. The Rosco LeverLock system utilizes a position lock that withstands the harshest vibrations and road environments.

Surround View Camera System

Series Cameras Deliver Coverage Of The Bus Where It's Needed Most.

SAFE-T-SCOPE® 180°	SAFE-T-SCOPE® 270°	SAFE-T-SCOPE® 360°
SAFE-T-SCOPE® 180°	SAFE-T-SCOPE® 270°	SAFE-T-SCOPE® 360°
2 Cameras 	3 Cameras 	4 Cameras
Each camera with 180° Field of Vision allows the driver to see in front and behind the bus	Each camera with 180° Field of Vision allows the driver to see in front, the right side loading area, and behind the bus	Each with 185° Field of Vision allows the driver to see everything around the bus

ALL KITS INCLUDE CAMERAS & HARNESSING ONLY. MONITORS MUST BE SELECTED SEPARATELY.

MANY MONITOR OPTIONS ARE AVAILABLE, SUCH AS:



[STSM630 / 530]
[MOR-VISION® 6X30 MIRROR WITH 7" MONITOR]
* OTHER MONITOR OPTIONS AVAILABLE *

SCREEN RECORDING AVAILABLE WITH DUAL-VISION® XC4 RECORDING CAMERA.



[DV440]
[DUAL-VISION® XC4 HD RECORDING CAMERA]

SAFE-T-SCOPE® 360HD

360° HD Surround View Camera System



The 360HD system utilizes four 192° field-of-vision cameras to offer drivers 3 dimensional views around the school bus. The enhanced 3D views enable the driver to see the bus at all angles, covering crucial blind zones where visibility is otherwise lost.



Features

Cameras	(4) 192° Field of View Cameras for optimal coverage around the vehicle.
Monitor	The Rosco monitor displays a high brightness image of the vehicle and the vehicle's blind spots.
Image Stitching	The image stitching capability of the Safe-T-Scope 360™ system provides a 3D HD 360° perimeter view around vehicle.
Image Views	The Safe-T-Scope 360HD™ allows for multiple views to enhance points of focus during vehicle operation. (ie: Vehicle rear in reverse)

Benefits

- + Meets the requirements of FMVSS 111 rear visibility standards.
- + Increase driver awareness.
- + Provide visual coverage of blind zones that are pertinent to large vehicles.
- + Reduce risk of collisions with Vulnerable Road users (VRUs).
- + Provide clear vision on sides of vehicles for narrow roadways.
- + Expanded side vision when reversing into a blind zone.

Models Available

	TYPE C	TYPE D
	STSK360303BC	STSK360303BD
	STSK360303TC	STSK360303TD
	STSK360303NC	STSK360303ND



Continuous HD Video Recording



Features	DV6	DV4
# Of Cameras	2 (expandable to 6)	2 (expandable to 10)
Dimensions	5.08" x 2.41" x 4.01"	3.7" x 4.13" x 2"
Camera Specifications	C1: 1080p, C2: 1080p	C1: 720p, C2: 960h
Camera Viewing Angles	C1: 116°Dia, C2: 116°Dia	C1: 135°Dia, C2: 160°Dia
G-Sensor	built-in 3-axis accelerometer	built-in 3-axis accelerometer
Audio	internal microphone for C2	internal microphone for C2
Gps	built-in gps w/ antenna	built-in gps w/ antenna
Can Bus	yes	no
DMS Ai Alerts	built-in	
Parking Mode	yes	yes
Driver Event Button	built-in	built-in / external
Speakers (Alerts)	yes	yes
Adjustable Video Quality	yes	yes
Adjustable Frame Rate	yes	yes
Light Sensor & Ir Leds	yes	yes
Modem	built-in	external mini router
Local Storage	micro sd (up to 1TB)	sd (up to 512GB)
RoscoLive Connectivity	required	optional
ADAS	yes	no
Driver ID	QR-Code scan via DV6 front cam	requires separate hardware DR101

Dual-Vision®

Designed with security in mind, the next generation of Rosco's Dual-Vision® camera allows you to drive with confidence. The DV6 is a compact camera that employs smart security to protect your drivers and fleet. Rosco's new DV6 captures and processes full HD footage of the driver and the road with local and cloud storage options. It generates in-cab alerts for drivers when risky behaviors are detected, and provides data for fleet managers to help monitor safety trends over time.



DV6

PN: DV660
Comes with 128GB SD.
Up to 1 TB of local storage.



DV4

PN: DV440
Comes with 128GB SD.
Up to 512GB of local storage.

The newest additions to DV6

DV6 now supports up to 6 views w/ the addition of the HD video converter + HD multiplexer.

The following camera types can be offered with DV6 to add 4 additional views depending on fleet requirements.

- Exterior side cameras (Left/Right, Front, Rear)
- Backup camera
- Additional interior camera (ie: for long passenger buses)
- Trailer camera
- Interior cargo camera + more...

Event Alert!

"Camera Obstruction" is triggered if the in-cab facing lens cannot fully detect the driver's face while the vehicle is in operation.

These can include, but are not limited to:

- Sun visor in down position (poor mounting location)
- Items hanging from the interior rearview mirror (ie: air fresheners)
- Rearview mirror (poor mounting location)
- Intentional lens covering (ie: hat on camera lens)
- Driver's face is outside of camera frame

Road Facing AI

- Forward Collision Warning
- Headway Monitoring
- Tailgating



Fleet Management

ROSCOLive®

REAL-TIME ACCESS TO YOUR FLEET

Event videos from the DV4 and DV6 cam are available on RoscoLive in real-time via 4G LTE connection – fully tested and certified by major carriers including Verizon, AT&T, and T-Mobile.

THE POWER OF DATA & VIDEO

Put yourself in the driver seat with powerful tools like trip replay. Go where your drivers go, and see what your drivers see. RoscoLive helps fleets managers and drivers work together to optimize productivity.

VALUABLE DATA & KNOWLEDGE

Get the whole story. RoscoLive offers customizable datasets on Events, drivers, vehicles, etc. to gather valuable insights for fleet efficiency.

EFFORTLESS MAINTENANCE WITH OTA

RoscoLive offers over-the-air maintenance for easy hardware maintenance. Remotely upgrade DV6 firmware and format your SD card without removing it from the device!

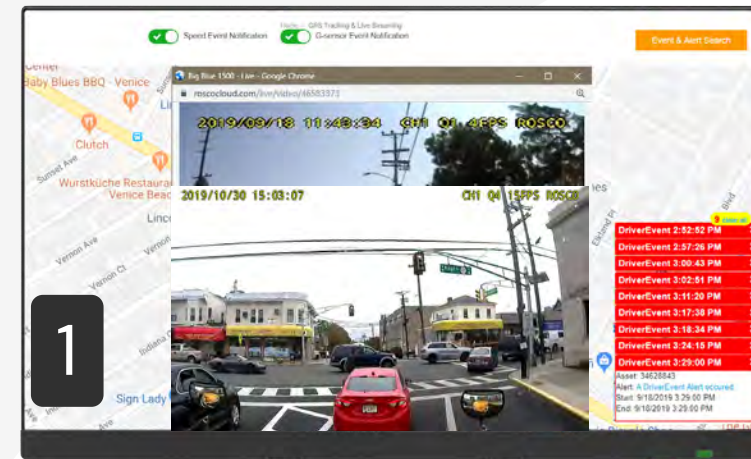

FRONT CAM



SIDE CAM



BACKUP CAM



DRIVER CAM

Improved user interface of RoscoLive® offers new experience with GPS tracking, live streaming video and customized reporting. See where all of your vehicles are in real time, using a single interface with full Google Maps functionality. RoscoLive allows you to watch and flag incident footage, stream video live from a vehicle, or share and download recordings.

Collision Avoidance Technology



Integrating collision avoidance technology for the next level of safety

The Mobileye® Advanced Driver Assistance System (Single Cam Kit) and Shield+™ System (Multi-Cam Kit) are the most effective technologies for preventing collisions between vehicles and Vulnerable Road Users (VRUs) including pedestrians and cyclists.



SMART SIDE SENSORS ARE ONLY AVAILABLE FOR SHIELD+ VERSION

VRUs often are not seen by the bus operator due to large blind spots around the vehicle, especially when making turns. Mobileye Collision Avoidance systems increase awareness and safety for the driver and VRUs around the bus to prevent collisions.

When a threat of a collision is high, Mobileye alerts give drivers the vital seconds needed to take corrective action.



FORWARD FACING COLLISION WARNINGS



+ Lane Departure Warning



+ Speed Limit Indication



+ Pedestrian and Cyclist Warning



+ Headway Monitoring & Event Warning



+ Urban Forward Collision Warning & Forward Collision Warning

Mobileye® Shield+ 4

3 CAM KIT

COLLISION AVOIDANCE W/ VRU SIDE SENSING CAPABILITIES



Integrating Mobileye Technology with Rosco's Dual-Vision XC4 enables real-time video feedback as the Mobileye System triggers alerts & warnings.

PEDESTRIAN & CYCLIST SIDE SENSING ONLY AVAILABLE WITH SHIELD+



Mobileye® A.D.A.S. SINGLE CAM KIT

GET IMPORTANT FORWARD FACING COLLISION ALERTS



Driven by safety - an AI-powered fleet safety solution. Prevent collisions, improve driver performance, and keep pupils safe. Act to prevent collisions with real-time alerts day or night. With Mobileye's latest technology, you get night detections, more accuracy, and greater range of detection.



SIDE SMART SENSORS ARE ONLY AVAILABLE FOR SHIELD+ VERSION



MOBILEYE ADAS 1CAM



MOBILEYE SHIELD+ 3 CAM

Collision avoidance features	Standard forward detection system	Right and left side ,and forward detection system
Lane Departure Warning	✓	✓
Speed Limit Indication	✓	✓
Forwards Pedestrian & Cyclist (VRU) Warning	✓	✓
Headway Monitoring & Event Warning	✓	✓
Forward Collision Warning	✓	✓
Urban Forward Collision Warning	✓	✓
VRU Detecting Side Sensors	-	✓
Large Displays	-	✓

D• CAMS

Digital Camera and Monitor System



FLAT LENS
Class II FOV

CONVEX LENS
Class IV FOV



Low light conditions

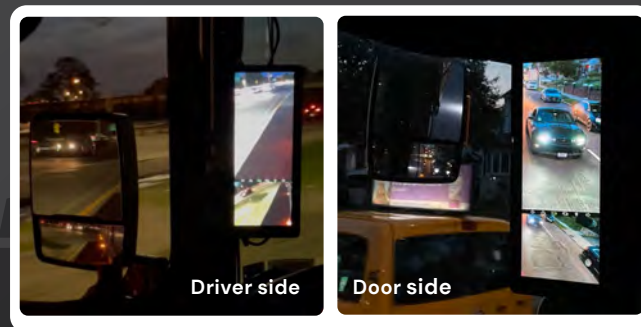

The new mirrorless camera system! Offering better visibility around the vehicle, the Rosco D•CAMS has been engineered to replace exterior rear vision mirrors on commercial vehicles.

The digital cameras cover views shown in both the flat lens and convex lens of rear view mirror.



traditional mirror view during rainy weather

highly improved visibility when using rosco's dcams

- Wider and deeper Field-of-View (FOV)
- Smaller blind zones
- Better visibility and brighter images during the day and night
- Clearer images in all weather conditions
- Aerodynamic design offers fuel savings and efficient operations
- Small camera profiles and high mounting locations to lessen impacts with objects

Rosco-DCams.com

From mirrors to AI-powered cameras, safety in pupil transportation is our #1 priority.

OUR MISSION

Turning tomorrow's technology into powerful solutions for today's vehicles.

OUR VISION

Creating a safe and sustainable world through innovative technologies, smart vehicles and connected fleets.

Rosco, Inc. is a leading global supplier of vision safety solutions to the bus and truck marketplace. With over 115 years of engineering and manufacturing experience, Rosco has been at the forefront of developing intelligent solutions that make America's roads safer.

Since 1907, Rosco has been headquartered in New York City, where our team of skilled engineers and technicians work tirelessly to engineer, manufacture and support our products. All of their products are made in the USA, ensuring the highest quality and craftsmanship.

As the largest manufacturer of bus mirrors in North America, Rosco has earned a reputation for excellence and innovation. We offer a range of products, from AI-powered cameras and recording

to cutting-edge collision avoidance systems, cloud-based SaaS platforms for vehicles, and more.

At Rosco, our mission is to provide drivers with the tools needed to stay safe on the road. We understand the importance of reliable and efficient transportation, and we are committed to developing the most advanced technology to help our customers achieve their goals.

So whether you're a driver, fleet operator, or transportation manager, Rosco has the vision safety solutions you need to keep your vehicles and your drivers safe on the road. Trust Rosco to provide you with the best in intelligent solutions for safer roads.



rosco
VISION

**Over 115 years of
automotive vision safety.**